

1 TYPICAL LOUVER PLAN AND ELEVATION

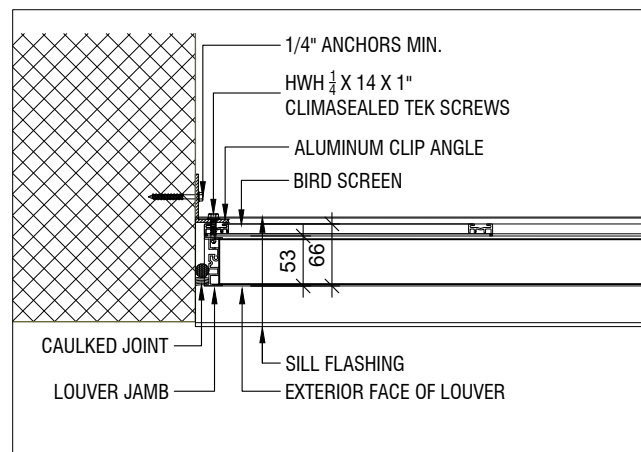

5 TYPICAL LOUVER JAMB DETAIL

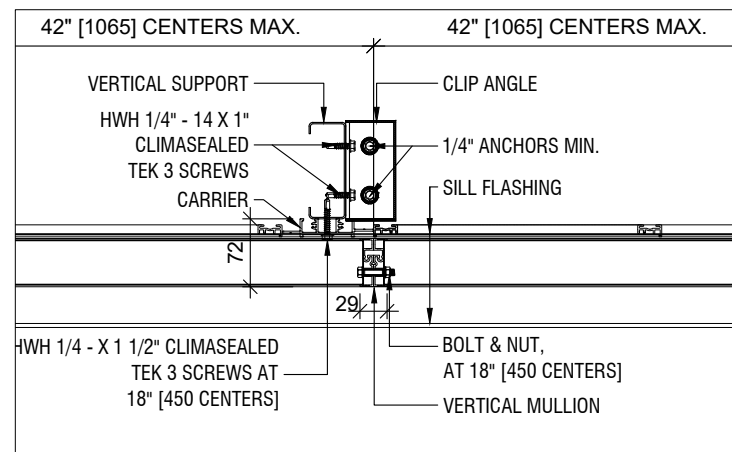

6 SUPPORT CONNECTION DETAIL AT VERTICAL LOUVER JOINT

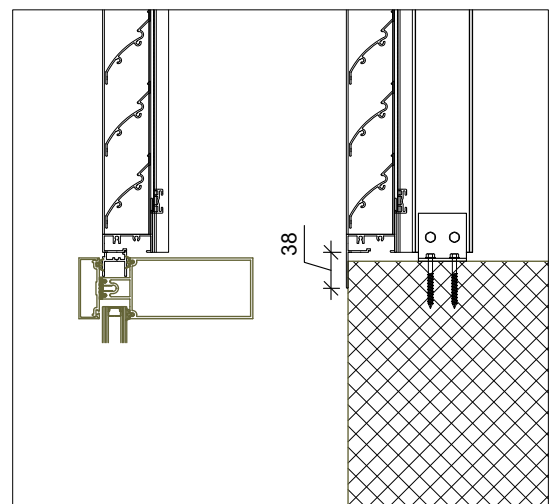

7 GLAZING AND FLANGE FRAME DETAIL OPTIONS

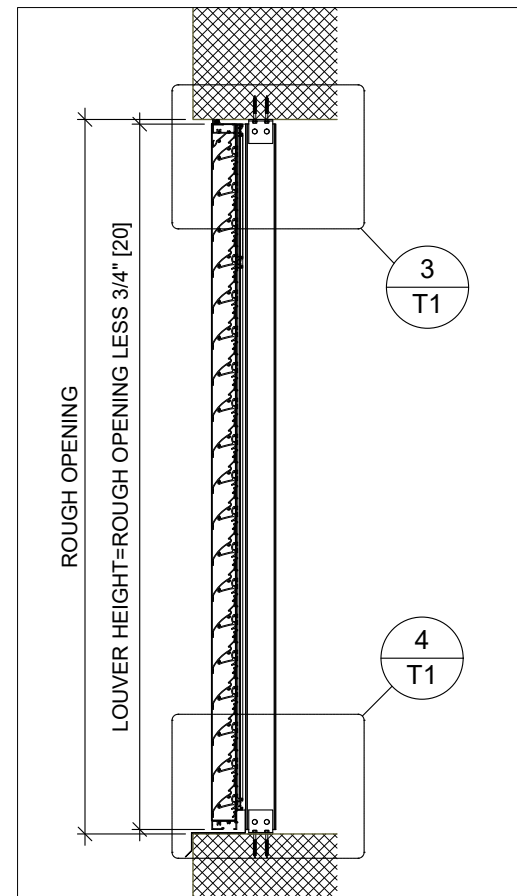

2 TYPICAL LOUVER SECTION

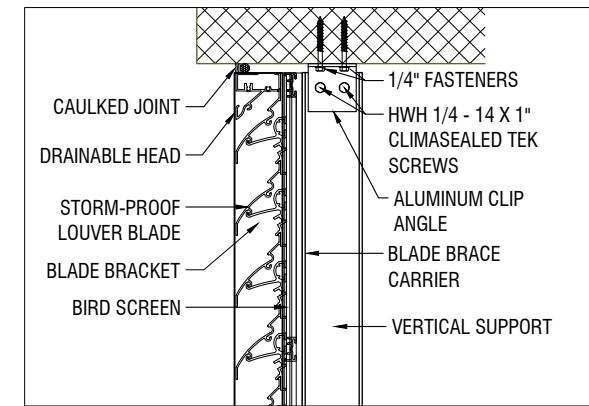

3 TYPICAL LOUVER HEAD DETAIL

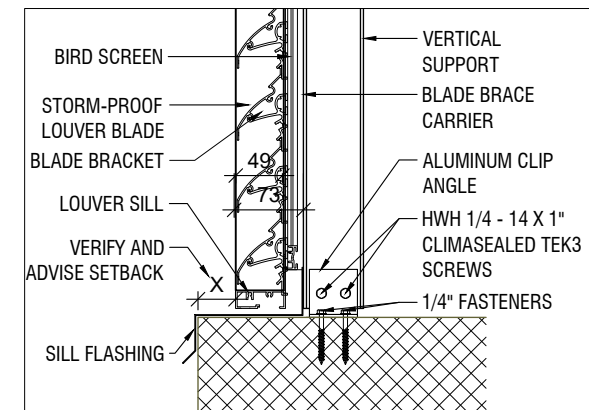

4 TYPICAL LOUVER SILL DETAIL

LOUVER SPECIFICATION:

TEN PLUS MODEL H2451 - EXTRUDED ALUMINUM LOUVER. ALL PROFILES TO BE 1.6 mm (0.062") 6063-T5 ALUMINUM ALLOY. UNLESS OTHERWISE SPECIFIED, ALL STRUCTURAL ELEMENTS TO BE DESIGNED FOR A LIVE LOAD OF 0.95 kPa (20 Lbs. PER SQ FOOT).

FINISH:

- THREE COAT 70% PVDF RESIN TO AAMA 2605 STD.
- TWO COAT 70% PVDF RESIN TO AAMA 2605 STD.
- ONE COAT THERMOSETTING RESIN TO AAMA 2603 STD.
- COLOR ANODIC
- COLOR: _____
- CLEAR ANODIZED CLASS I CLASS II
- OTHER: _____

BLANK OFF PANEL:

- 1 mm (0.040") ALUMINUM SHEET ONLY
- INSULATED / THICKNESS: _____
- EXTERIOR SHEET PAINTED TO MATCH LOUVER

SCREENS:

- 16 mm (5/8") EXPANDED ALUMINUM MESH
- 12 mm (1/2") WELDED & REGALVANIZED STEEL MESH
- 12 mm (1/2") INTER-CRIMPED ALUMINUM WIRE
- 18 X 18 ALUMINUM MESH INSECT SCREEN
- OTHER: _____

OTHER:

- SILL FLASHING REQUIRED
- LOUVER SETBACK DIM. _____
- GLAZING FRAME OPTION
- FLANGE FRAME OPTION
- _____
- _____

NOTE: SOME OPTIONS MAY LEAD TO EXTRA COSTS TO THE CONTRACT. ENQUIRE WITH YOUR REP.

MODEL H2451

revisions:	
issued for client review	2023-00-00

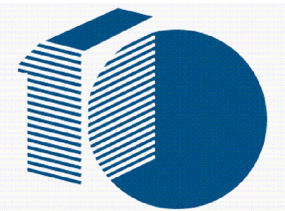

TENPLUS
ARCHITECTURAL PRODUCTS LTD.
5-2333 MILLRACE COURT
MISSISSAUGA, ON L5N 1W2
TEL: 905-363-2306
FAX: 905-363-2309
WWW.TENPLUS-ONLINE.COM

PROJECT:

SPEC. SECTION:

CUSTOMER:

ARCHITECT:

TEN PLUS CONTACT:

DRAWN BY:

SCALE:
AS NOTED

CHECKED BY:

DRAWING:

MODEL H2451 STORM BLADE LOUVER

JOB No.

DWG No.