

1 TYPICAL LOUVER PLAN AND ELEVATION

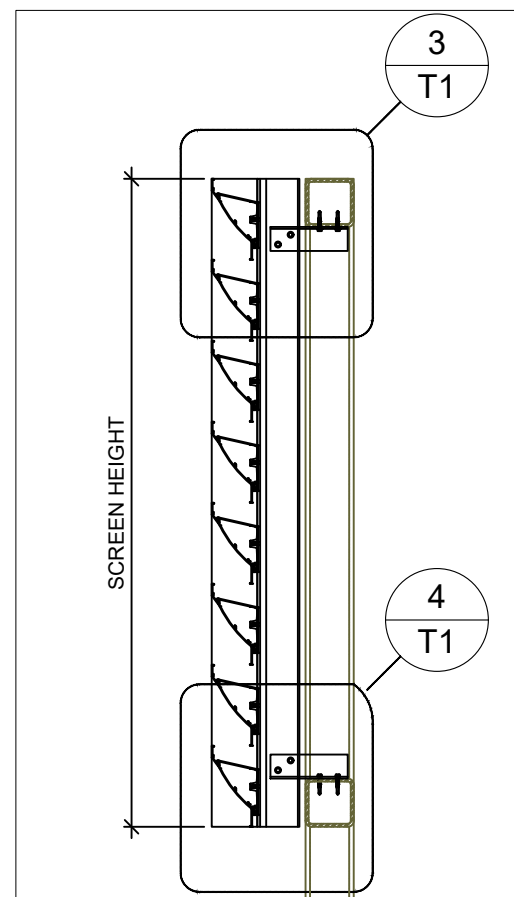

2 TYPICAL LOUVER SECTION

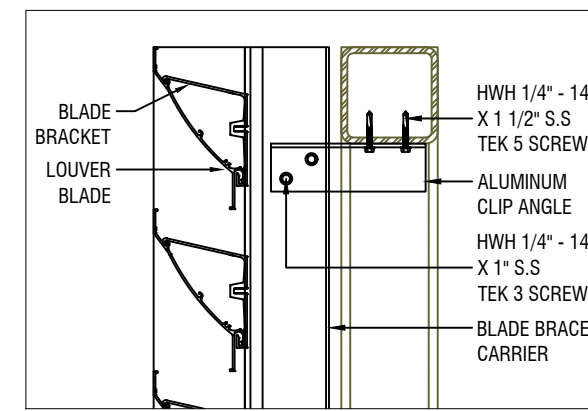

3 TYPICAL LOUVER HEAD DETAIL

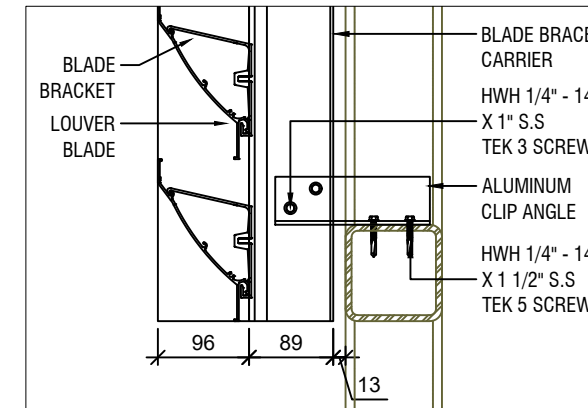

4 TYPICAL LOUVER SILL DETAIL

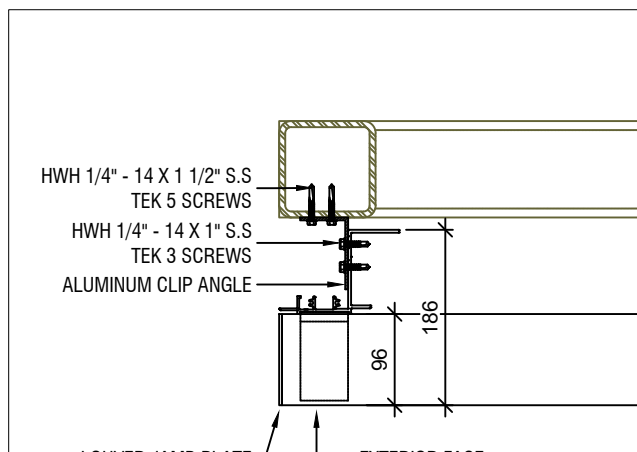

5 TYPICAL LOUVER JAMB DETAIL

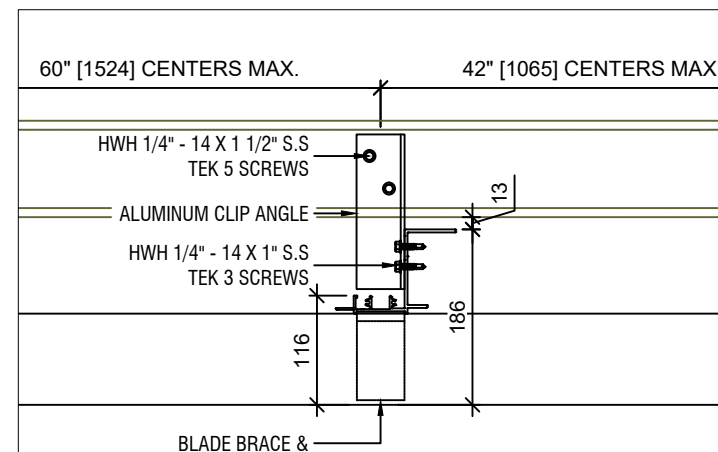

6 TYPICAL VERTICAL SUPPORT CONNECTION DETAIL

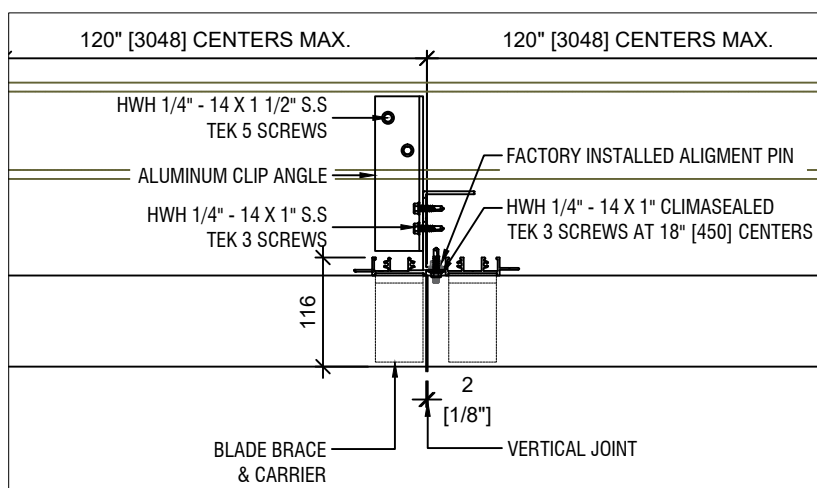

7 SUPPORT CONNECTION DETAIL AT VERTICAL LOUVER JOINT

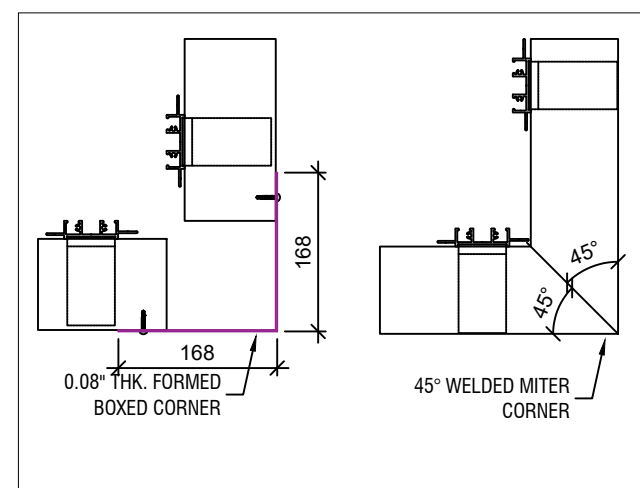

8 GLAZING AND FLANGE FRAME DETAIL OPTIONS

**LOUVER SPECIFICATION:**

TEN PLUS MODEL S4522 - EXTRUDED ALUMINUM LOUVER. ALL PROFILES TO BE 2 mm (0.080") 6063-T5 ALUMINUM ALLOY. UNLESS OTHERWISE SPECIFIED, ALL STRUCTURAL ELEMENTS TO BE DESIGNED FOR A LIVE LOAD OF 0.95 kPa (20 Lbs. PER SQ FOOT).

**FINISH:**

- THREE COAT 70% PVDF RESIN TO AAMA 2605 STD.
- TWO COAT 70% PVDF RESIN TO AAMA 2605 STD.
- ONE COAT THERMOSETTING RESIN TO AAMA 2603 STD.
- COLOR ANODIC
- COLOR: \_\_\_\_\_
- CLEAR ANODIZED  CLASS I  CLASS II
- OTHER: \_\_\_\_\_

**BLANK OFF PANEL:**

- 1 mm (0.040") ALUMINUM SHEET ONLY
- INSULATED / THICKNESS: \_\_\_\_\_
- EXTERIOR SHEET PAINTED TO MATCH LOUVER

**SCREENS:**

- 16 mm (5/8") EXPANDED ALUMINUM MESH
- 12 mm (1/2") WELDED & REGALVANIZED STEEL MESH
- 12 mm (1/2") INTER-CRIMPED ALUMINUM WIRE
- 18 X 18 ALUMINUM MESH INSECT SCREEN
- OTHER: \_\_\_\_\_

**OTHER:**

- SILL FLASHING REQUIRED
- LOUVER SETBACK DIM. \_\_\_\_\_
- GLAZING FRAME OPTION
- FLANGE FRAME OPTION
- \_\_\_\_\_
- \_\_\_\_\_

NOTE: SOME OPTIONS MAY LEAD TO EXTRA COSTS TO THE CONTRACT. ENQUIRE WITH YOUR REP.

**NOTES:**

**MODEL S4522**

revisions:	
issued for client review	2023-00-00

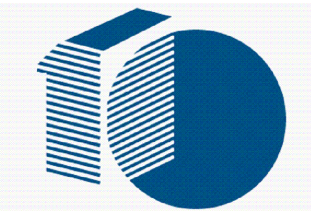

**TENPLUS**  
ARCHITECTURAL PRODUCTS LTD.  
5-2333 MILLRACE COURT  
MISSISSAUGA, ON L5N 1W2  
TEL: 905-363-2306  
FAX: 905-363-2309  
WWW.TENPLUS-ONLINE.COM

PROJECT:

SPEC. SECTION:

CUSTOMER:

ARCHITECT:

TEN PLUS CONTACT:

DRAWN BY:

SCALE:  
AS NOTED

CHECKED BY:

DRAWING:

MODEL S4522 VISION SCREEN

JOB No.

DWG No.